

Keysight E5061B Network Analyzer

100 kHz to 1.5 GHz/3 GHz

5 Hz to 3 GHz

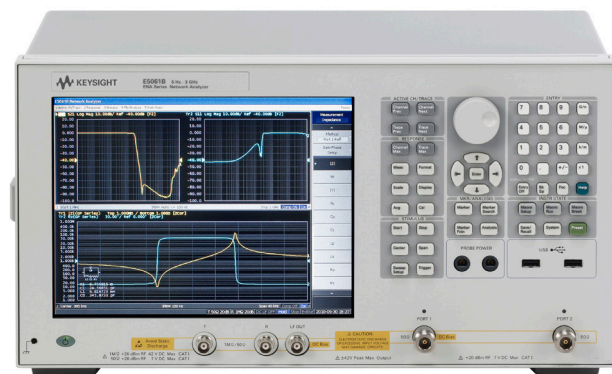

Unlocking Measurement Insights

E5061B Responds to Various Measurement Needs, From LF to RF

The Keysight Technologies, Inc. E5061B is a member of the industry standard ENA Series network analyzers. The E5061B addresses a broad range of measurement needs of electronic components and circuits from low to high frequencies. The E5061B is the ideal solution for applications in industries such as wireless communications, aerospace and defense, computer, medical, automotive, CATV, plus many more. The E5061B now provides a new standard of frequency-domain device analysis from 5 Hz to 3 GHz.

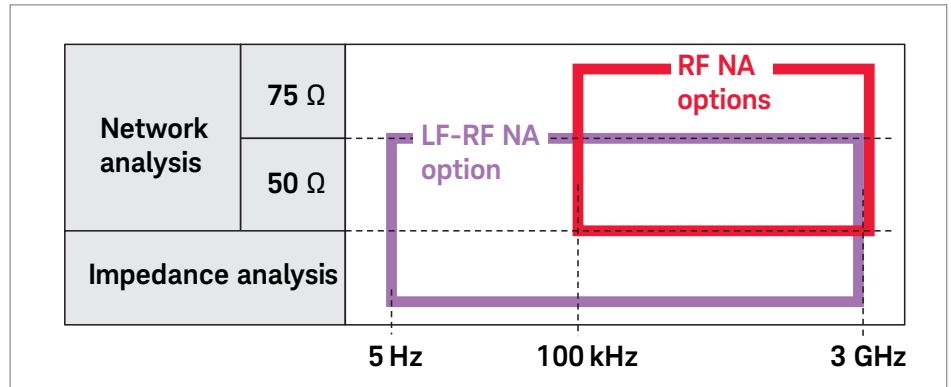

RF NA options

E5061B-115/215/135/235: 50 Ω

E5061B-117/217/137/217: 75 Ω

Economy RF network analyzer that offers solid performance for basic RF network measurements

- 100 kHz to 1.5 GHz/3 GHz
- Transmission/Reflection test set and S-parameter test set
- 50 Ω and 75 Ω system impedance
- Wireless power transfer analysis function (Option 006)²

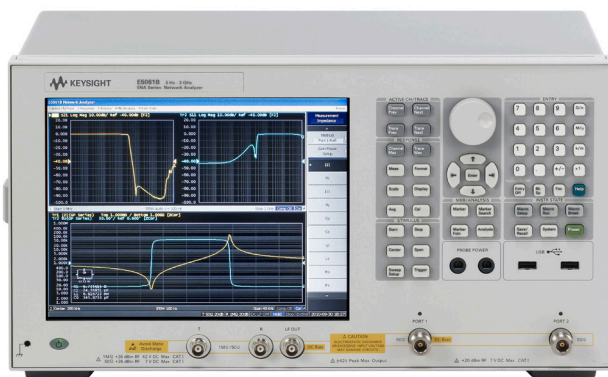

LF-RF NA option

E5061B-3L5

General-purpose network analyzer with comprehensive functionality to support network and impedance measurements for electronic devices from LF to RF

- 5 Hz to 3 GHz
- 50 Ω S-parameter test set
- Gain-phase test port (1 M Ω /50 Ω inputs)
- DC bias source
- Impedance analysis function (Option 005)¹
- Wireless power transfer analysis function (Option 006)

1. Option 005 impedance analysis function is not applicable on the RF NA Options E5061B-1x5/2x5/1x7/2x7.
 2. Option 006 wireless power transfer analysis function is not applicable on the RF NA Options E5061B-1x5/1x7/2x7.

Advanced Measurement Capabilities in a Compact Box

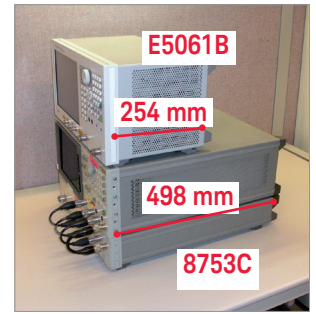
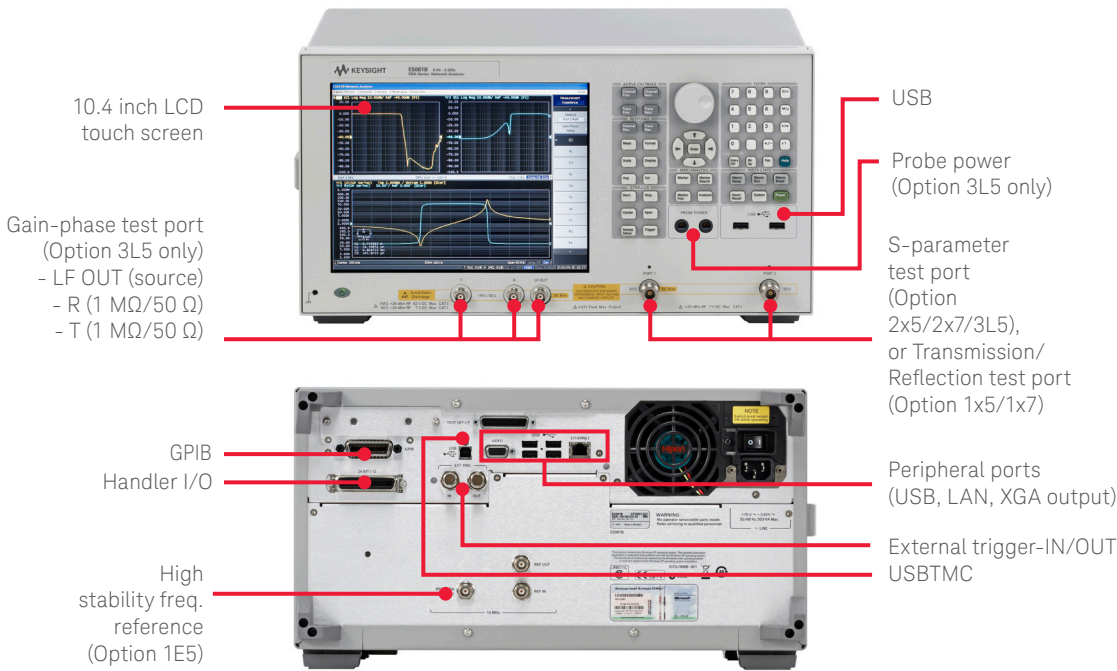

Compact body (Comparison with 8753C network analyzer)

Table 1. E5061B key measurement functions

	RF NA options (E5061B-1x5/2x5/1x7/2x7)	LF-RF NA option (E5061B-3L5)
Test frequency range	100 kHz to 1.5 GHz (Option 115/215/117/217) 100 kHz to 3 GHz (Option 135/235/137/237)	5 Hz to 3 GHz
Source output level	-45 to +10 dBm (at 300 kHz to 1.5/3 GHz) -45 to +5 dBm (at 100 kHz to 300 kHz)	-45 to +10 dBm (at 5 Hz to 3 GHz)
Dynamic range	>120 dB (at 1 MHz to 1.5/3 GHz, IFBW = 10 Hz)	>120 dB (at 1 MHz to 3 GHz, IFBW = 10 Hz)
Trace noise	5 mdBrms (IFBW=3 kHz)	5 mdBrms (IFBW=3 kHz/Auto)
Test port	Transmission/Reflection (Option 1x5/1x7), or S-parameter test port (Option 2x5/2x7)	S-parameter test port (5 Hz to 3 GHz), plus Gain-phase test port (5 Hz to 30 MHz)
75 Ω test port	Yes (option 1x7/2x7)	No
1 MΩ input	No	Yes (Gain-phase test port, 1 MΩ // 30 pF)
Probe power	No	Yes
DC bias source	No	Yes (0 to ±40 Vdc, max. 100m Adc, sweepable)
Impedance analysis function	No	Yes (Option 005)
Wireless power transfer analysis function	Yes (Option 006) ¹	Yes (Option 006)
Frequency stability (CW accuracy)	±7 ppm ±1 mHz (standard), ±1 ppm ±1 mHz (option 1E5)	
Time domain/Fault location analysis	Yes (option 010, with Time gating and Structural Return Loss analysis functions)	
Number of channels/traces	4-channel/4-trace	
Number of point	1601 points	
IFBW	1 Hz to 300 kHz, plus IFBW Auto mode (Option 3L5 only)	
Calibration capabilities	Response, 1-port full, 2-port full ² , Enhanced response, Adapter removal, Auto port extension ECal (at >300 kHz with RF 2-port ECal modules) Impedance calibration and fixture compensation (Option 3L5 + 005 only)	
Data analysis, data processing	Equation editor, VBA programming, Limit test, Z-conversion	

1. Not available with E5061B-1x5/1x7/2x7.

2. Not available with E5061B-115/135/117/137.

RF NA Options (100 kHz to 1.5/3 GHz)

E5061B-115/215/135/235: 50 Ω,
E5061B-117/217/137/237: 75 Ω

Solid performance in an enhanced platform

The E5061B RF NA options provide high-performance 1- and 2-port network analysis at an affordable price. The established RF performance of the E5061/62A has been integrated into this new digital platform. A wide variety of test set options allows you to select the best configuration to suite your test requirements and budget. Enhanced digital processing capabilities and a smaller footprint improve the throughput and efficiency for testing RF components, including cellular BTS filters/antennas, MRI coils, RFIDs, CATV components, and more.

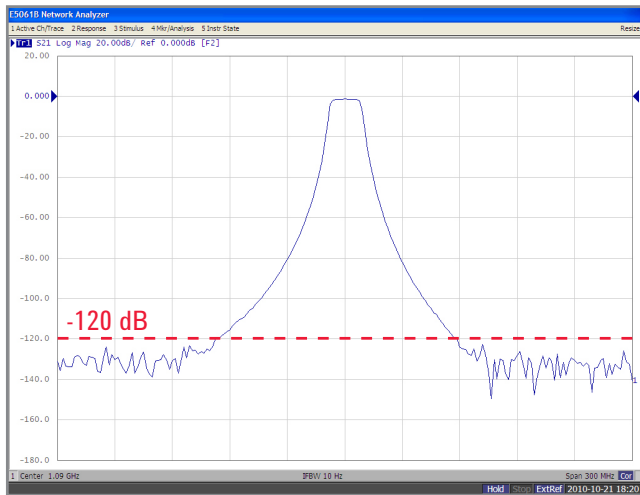

Wide dynamic range for RF filter measurement
(F0 = 1.09 GHz, source = 10 dBm, IFBW = 10 Hz)

Expanded frequency range

An expanded lower-end frequency range down to 100 kHz allows you to test components that require measurements in the 100 kHz range, such as LAN filters and automotive antennas.

Time domain/Fault location analysis (Option E5061B-010)

The time gating function is available in the time domain/fault-location analysis function. This enables you to eliminate mismatch errors caused by test fixtures when testing CATV cables.

Transmission/Reflection test set	S-parameter test set
#115 : 1.5 GHz, 50 Ω	#215 : 1.5 GHz, 50 Ω
#135 : 3 GHz, 50 Ω	#235 : 3 GHz, 50 Ω
#117 : 1.5 GHz, 75 Ω	#217 : 1.5 GHz, 75 Ω
#137 : 3 GHz, 75 Ω	#237 : 3 GHz, 75 Ω

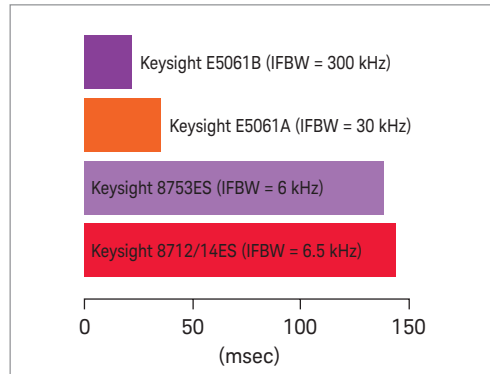
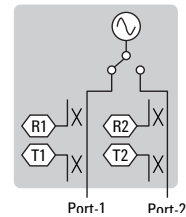
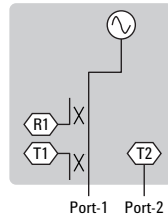

Sweep speed comparison (201 points, 2-port cal, max IFBW)

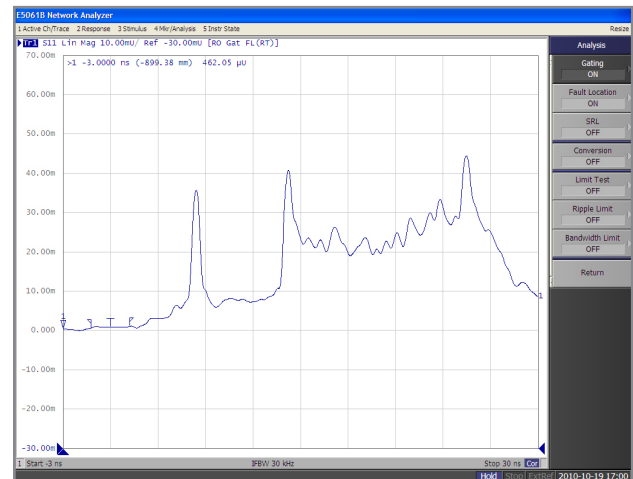

Time domain analysis for cable

LF-RF NA Option (5 Hz to 3 GHz) E5061B-3L5

Comprehensive LF-to-RF network analysis

The E5061B-3L5 LF-RF NA option offers versatile network analysis in the broad frequency range from 5 Hz to 3 GHz. Comprehensive LF network measurement capabilities including built-in 1 MΩ inputs have been seamlessly integrated with the high-performance RF network analyzer. The E5061B-3L5 is the right solution for component and circuit evaluations in the R&D environment.

S-parameter test port

The built-in S-parameter test set of the E5061B-3L5 fully covers 5 Hz to 3 GHz with excellent dynamic range performance. This allows you to evaluate a variety of devices from near DC to RF ranges.

Gain-phase test port

The gain-phase test port provides direct receiver access for LF applications from 5 Hz to 30 MHz. The built-in 1 MΩ inputs allow you to easily perform in-circuit probing measurements for amplifiers and DC-DC converter control loops. The receiver ports can accurately measure amplifier's CMRR/PSRR and PDN milliohm impedance by eliminating the measurement errors associated with the ground loop.

DC bias source

The E5061B-3L5 has a built-in DC bias source which internally superimposes the DC voltage up to ±40 Vdc onto the AC source signal at port-1 or LF OUT port. Also, it is possible to provide only the DC voltage from LF OUT port while measuring a DUT at the S-parameter test port.

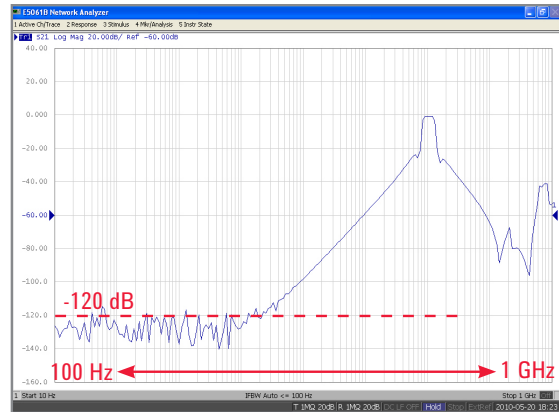
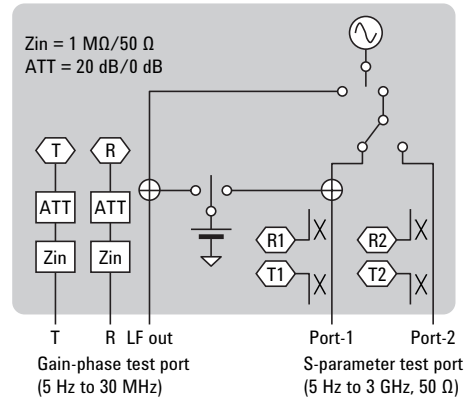
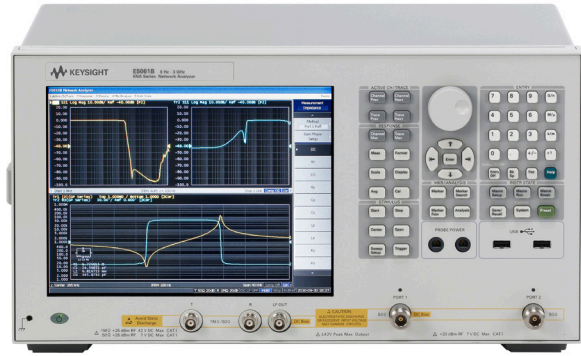

Wide-band S21 measurement with S-parameter test port

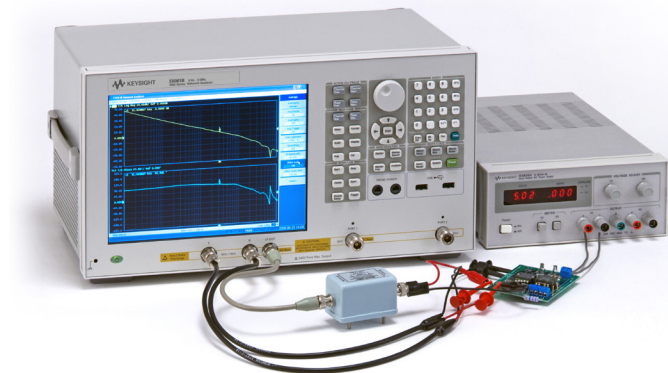

DC-DC converter loop-gain measurement with gain-phase test port

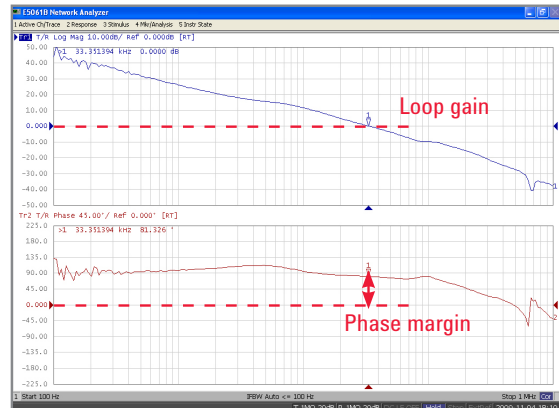

DC-DC loop-gain measurement

LF-RF NA Option (5 Hz to 3 GHz) E5061B-3L5 + 005 Impedance Analysis Option

NA plus ZA in one box

The E5061B-005 provides the impedance analysis (ZA) firmware for the E5061B-3L5 LF-RF network analyzer. This option enables the analyzer to measure impedance parameters of electronic components such as capacitors, inductors, and resonators. The combination of NA and ZA capabilities further enhances the analyzer's versatility as a general R&D tool. Basic ZA functionalities including fixture compensation and equivalent circuit analysis are supported by the firmware. The DC biased impedance measurement is possible with the built-in DC bias source provided by the E5061B-3L5.

Wide application coverage

The E5061B-005 supports reflection, series-thru, and shunt-thru methods using the S-parameter test port or gain-phase test port. These methods are ideally suitable for low-to-middle, middle-to-high, and very low milliohm impedance ranges. You can evaluate a broad range of components by selecting appropriate measurement methods.

Test fixtures

For the port-1 reflection method and the gain-phase series-thru method, you can use Keysight's 7 mm and 4TP (4-terminal-pair) component test fixtures. The 7 mm fixtures are connected to the port-1 via the 16201A terminal adapter, and the 4TP fixtures are directly connected to the gain-phase test port.

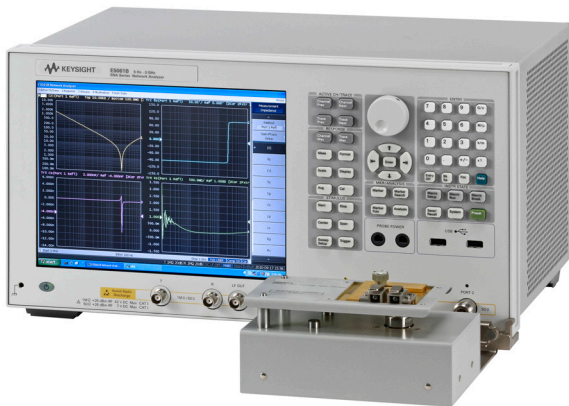
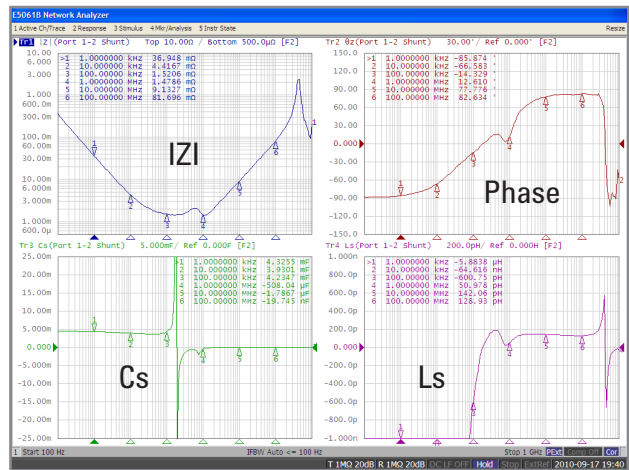
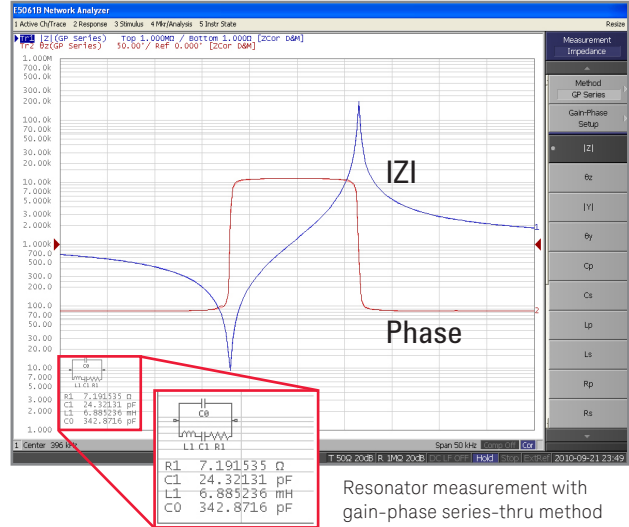

Port-1 reflection method using 16201A terminal adapter and 16092A 7 mm type fixture

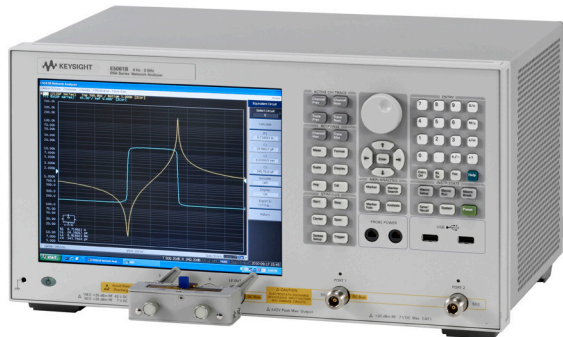

E5061B-006 Wireless Power Transfer Analysis Option

Power transfer efficiency between coils or resonators is one of the key factors to improve the performance of wireless power transfer systems. The Keysight E5061B offers option 006¹ wireless power transfer analysis software to measure wireless power transfer efficiency between coils or resonators. In addition, option 3L5 and 005 add power integrity and impedance measurement capabilities to achieve combination analysis in one-box.

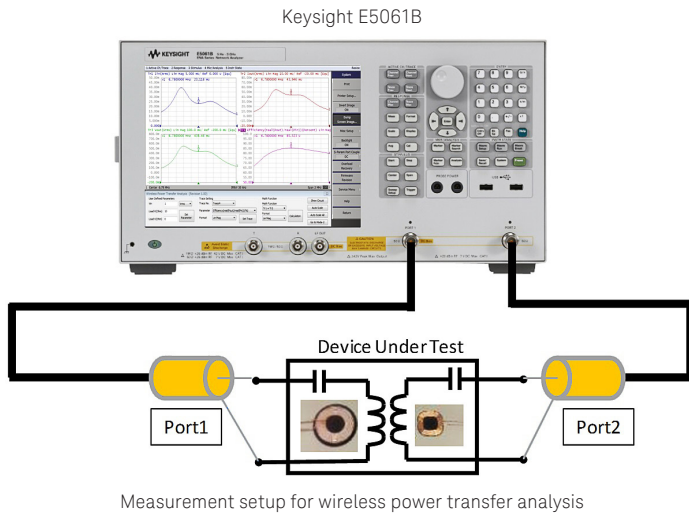

Real-time wireless power transfer efficiency measurements

- Display wireless power transfer efficiency between coils or resonators in real-time
- Capable of setting arbitrary load impedance

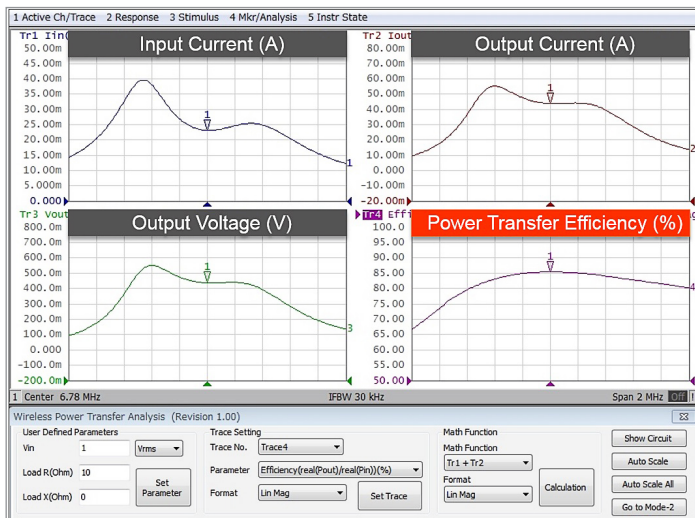

Advanced simulation

- 2D/3D simulation to visualize dependency of load impedance
- Network analysis data output for further circuit modeling and simulation in Keysight ADS simulator

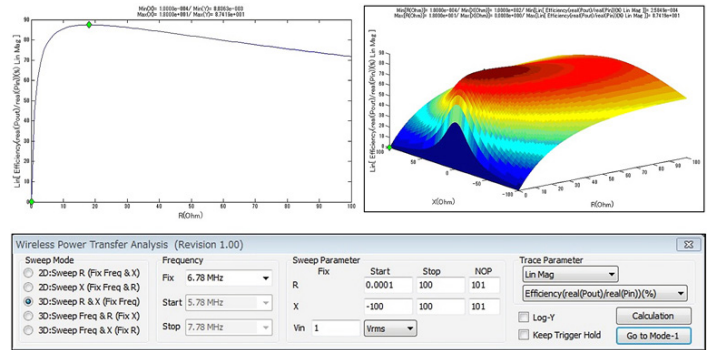

Combination analysis of power transfer, power integrity and impedance

- E5061B option 3L5 allows LF-RF network analysis from 5 Hz to 3 GHz
- E5061B option 005 adds impedance analysis function
- Wireless power transfer analysis, power integrity & impedance measurements in one-box



One-box solution for characterization of components in wireless power transfer systems

1. Option 006 is not applicable for the E5061B RF NA options 1x5/1x7/2x7

Ordering Information

E5061B network analyzer	
Test set options ¹	
50 Ω RF NA options	
E5061B-115	Transmission/Reflection test set, 100 kHz to 1.5 GHz, 50 Ω system impedance
E5061B-215	S-parameter test set, 100 kHz to 1.5 GHz, 50 Ω system impedance
E5061B-135	Transmission/Reflection test set, 100 kHz to 3 GHz, 50 Ω system impedance
E5061B-235	S-parameter test set, 100 kHz to 3 GHz, 50 Ω system impedance
75 Ω RF NA options	
E5061B-117	Transmission/Reflection test set, 100 kHz to 1.5 GHz, 75 Ω system impedance
E5061B-217	S-parameter test set, 100 kHz to 1.5 GHz, 75 Ω system impedance
E5061B-137	Transmission/Reflection test set, 100 kHz to 3 GHz, 75 Ω system impedance
E5061B-237	S-parameter test set, 100 kHz to 3 GHz, 75 Ω system impedance
LF-RF NA option	
E5061B-3L5	LF-RF network analyzer with DC bias source, 5 Hz to 3 GHz
Impedance analysis options (for E5061B-3L5)	
E5061B-005	Impedance analysis function for LF-RF network analyzer ²
E5061B-006	Wireless power transfer analysis function ³
E5061B-720	Add 50 Ω resistor set ⁴
Other options	
E5061B-1E5	High stability time base
E5061B-010	Time domain/Fault location analysis
E5061B-020	Standard hard disk drive ⁵
E5061B-810	Add keyboard
E5061B-820	Add mouse
E5061B-1CM	Rack mount kit
E5061B-1CN	Front handle kit
E5061B-1CP	Rack mount and front handle kit
E5061B-1A7	ISO 17025 compliant calibration
E5061B-A6J	ANSI Z540 compliant calibration
Accessories	
For network analysis	
Mechanical calibration kits	
85032E/F	Type-N 50 Ω calibration kit
85033E	3.5 mm 50 Ω calibration kit
85036B/E	Type-N 75 Ω calibration kit
85039B	Type-F 75 Ω calibration kit

ECal modules ⁶	
85092C	Type-N 50 Ω 2-port RF ECal module, 300 kHz to 9 GHz
85093C	3.5 mm 50 Ω 2-port RF ECal module, 300 kHz to 9 GHz
85096C	Type-N 75 Ω 2-port RF ECal module, 300 kHz to 3 GHz
85099C	Type-F 75 Ω 2-port RF ECal module, 300 kHz to 3 GHz
N4431B	50 Ω 4-port RF ECal module, 9 kHz to 13.5 GHz
Power splitter (for gain-phase test port)	
11667L	BNC-type power splitter, DC to 2 GHz
For impedance analysis	
Terminal adapter and calibration kit	
16201A	7 mm terminal adapter kit
16195B	7 mm calibration kit ⁷ (open/short/load, and low-loss-C)
85031B	7 mm calibration kit ⁷ (open/short/load)
7 mm test fixtures	
16092A	Test fixture, 500 MHz, for SMD and leaded DUT
16192A	SMD test fixture, 2 GHz
16196A/B/C/D	SMD test fixture, 3 GHz
16197A	SMD test fixture, 3 GHz
4-terminal-pair test fixtures	
16047E	Test fixture, for leaded DUT
16034E/G/H	SMD test fixture

1. Must choose one of the nine test set options.
2. Option 005 is not applicable for the E5061B RF NA Options 1x5/2x5/1x7/2x7.
3. Option 006 is not applicable for the E5061B RF NA Options 1x5/1x7/2x7.
4. For calibration at test fixtures. Required for the gain-phase series-thru method.
5. Option 020 is the only hard disk option for the E5061B. Must choose this option when ordering the E5061B.
6. The ECal modules cannot be used in the low frequency range below 300 kHz or 9 GHz.
7. For calibration at the 7 mm connector of the 16201A.

myKeysight

myKeysight

www.keysight.com/find/mykeysight

A personalized view into the information most relevant to you.



www.axiestandard.org

AdvancedTCA® Extensions for Instrumentation and Test (AXIe) is an open standard that extends the AdvancedTCA for general purpose and semiconductor test. Keysight is a founding member of the AXIe consortium. ATCA®, AdvancedTCA®, and the ATCA logo are registered US trademarks of the PCI Industrial Computer Manufacturers Group.



www.lxistandard.org

LAN eXtensions for Instruments puts the power of Ethernet and the Web inside your test systems. Keysight is a founding member of the LXI consortium.



www.pxisa.org

PCI eXtensions for Instrumentation (PXI) modular instrumentation delivers a rugged, PC-based high-performance measurement and automation system.



Three-Year Warranty

www.keysight.com/find/ThreeYearWarranty

Keysight's commitment to superior product quality and lower total cost of ownership. The only test and measurement company with three-year warranty standard on all instruments, worldwide.



www.keysight.com/go/quality

Keysight Technologies, Inc.
DEKRA Certified ISO 9001:2008
Quality Management System

Keysight Channel Partners

www.keysight.com/find/channelpartners

Get the best of both worlds: Keysight's measurement expertise and product breadth, combined with channel partner convenience.

For more information on Keysight Technologies' products, applications or services, please contact your local Keysight office. The complete list is available at: www.keysight.com/find/contactus

Americas

Canada	(877) 894 4414
Brazil	55 11 3351 7010
Mexico	001 800 254 2440
United States	(800) 829 4444

Asia Pacific

Australia	1 800 629 485
China	800 810 0189
Hong Kong	800 938 693
India	1 800 11 2626
Japan	0120 (421) 345
Korea	080 769 0800
Malaysia	1 800 888 848
Singapore	1 800 375 8100
Taiwan	0800 047 866
Other AP Countries	(65) 6375 8100

Europe & Middle East

Austria	0800 001122
Belgium	0800 58580
Finland	0800 523252
France	0805 980333
Germany	0800 6270999
Ireland	1800 832700
Israel	1 809 343051
Italy	800 599100
Luxembourg	+32 800 58580
Netherlands	0800 0233200
Russia	8800 5009286
Spain	800 000154
Sweden	0200 882255
Switzerland	0800 805353
	Opt. 1 (DE)
	Opt. 2 (FR)
	Opt. 3 (IT)
United Kingdom	0800 0260637

For other unlisted countries:
www.keysight.com/find/contactus
(BP-04-23-15)