

Keysight Technologies

PXI Vector Network Analyzer

M9370A 300 kHz to 4 GHz

M9371A 300 kHz to 6.5 GHz

M9372A 300 kHz to 9 GHz

M9373A 300 kHz to 14 GHz

M9374A 300 kHz to 20 GHz

M9375A 300 kHz to 26.5 GHz

Configuration Guide



Drive Down the Size of Test

This configuration guide describes standard configurations, options, accessories, upgrade kits and compatible peripherals for the M937xA PXIe vector network analyzer (VNA). This guide should be used with the Keysight PXI VNA data sheet for a complete description of these analyzers.

Table of Contents

A. Select Options for M937xA PXIe VNA.....	3
B. Select Controller (Embedded Controller)	4
C. Select Controller (Via PC).....	5
D. Select a Chassis and Accessories	6
E. Physical Connection Diagram for Controllers.....	7
F. Select Software for M937xA PXIe VNA	8
G. Select Services: Warranty, Calibration, Start-Up Assistance.....	9
H. Measurement Accessories.....	11
For devices with 3.5 mm or SMA connectors.....	12
For devices with Type-N connectors	13
For devices with 7 mm connectors	14
For devices with waveguide.....	14
I. Example Configurations.....	15
Single 2-port M937xA PXIe VNA	15
Multiport Measurement Configurations	15
Multi-site Measurement Configurations.....	17
Upgrading Your System.....	17
Using a Non-Keysight Chassis	18
PC Requirements for M937xA PXIe VNA Control	18
Related Literature	18

A. Select Options for M937xA PXIe VNA

Step 1. Start by choosing the frequency range of the M937xA PXIe VNA

- M9370A 300 kHz to 4 GHz
- M9371A 300 kHz to 6.5 GHz
- M9372A 300 kHz to 9 GHz
- M9373A 300 kHz to 14 GHz
- M9374A 300 kHz to 20 GHz
- M9375A 300 kHz to 26.5 GHz

Step 2. Add time domain capability (optional)

- M937xA-010 Time domain

Step 3. Add full N-port correction capability (optional)

- M937xA-551 N-port calibrated measurement¹

Step 4. Add multiport cable kit (optional)

- Y1242A Multiport cable kit

Includes 2 SMB cables and 1 SMA cables for connecting 2 modules together.

Add one multiport cable kit for each additional 2-port VNA

Step 5. Add multiport accessory and tool kit (optional)

- Y1281A Accessory and tool kit

Includes the following tools for SMA and SMB connector removal:
 5002-3361 Pull tool for SMB connectors
 5023-1450 Custom long deep socket for 3.5/SMA connector nuts

1. When ordering multiple VNA modules Option Y1242A is recommended for each additional multiport interconnection.

B. Select Controller (Embedded Controller)¹

Step 1. If selecting an embedded controller, select either M9036A or M9037A²

- M9036A Mid-performance embedded controller
Intel i5-520E dual-core, 2.4 GHz, 4 thread, 4 GB RAM
Select the M9036A for mid-performance, lower cost



- M9037A High-performance embedded controller
Intel i7-4700EQ quad-core processor, 2.4 GHz, 8 thread, 4 GB RAM
Select M9037A for the best performance if you have memory intensive applications, multiple applications running in parallel or if a lot of data is sent to the PC from the PXIe chassis. Features removable SSD drive for security and x8 connector from front for connection to second chassis



Step 2. Upgrade from standard memory size (optional)

For M9036A

- M9036A-M08 Memory upgrade from 4 GB to 8 GB RAM

For M9037A

- M9037A-M08 Memory upgrade from 4 GB to 8 GB RAM
- M9037A-M16 Memory upgrade from 4 GB to 16 GB RAM

Step 3. Select an operating system

For M9036A

- M9036A-WE3 Microsoft Windows Embedded Standard 7 (32-bit)
- M9036A-WE6 Microsoft Windows Embedded Standard 7 (64-bit)



For M9037A

- M9037A-WE3 Microsoft Windows Embedded Standard 7 (32-bit)
- M9037A-WE6 Microsoft Windows Embedded Standard 7 (64-bit)



1. For a list of qualified external controllers, please see Test Computer List Technical Note literature no. 5990-7632EN. The M9021A is used for both PC controllers and can only be used in the M9018A chassis.
2. The M9018A 18-slot chassis includes empty space to the left of the first functional slot. The embedded controller occupies that empty space and the first functional slot.

C. Select Controller (Via PC)¹

To use your Laptop PC as a controller

- M9045B	PCIe ExpressCard adaptor	
- Y1200B	PCIe cable	
- M9021A	PCIe cable interface ² : 1 slot	

To use your Desktop PC as a controller

- M9048A	PCIe desktop adaptor	
- Y1202A	PCIe cable	
- M9021A	PCIe cable interface ² : 1 slot	

1. For a list of qualified external controllers, please see *Test Computer List*, Technical Note literature number 5990-7632EN. See physical connections diagram in Section E.
2. The M9021A is used for either PC control option and can only be used with the Keysight M9018A 18-slot chassis.

D. Select a Chassis and Accessories

Step 1. Select a chassis

- M9018A 18-slot PXIe chassis

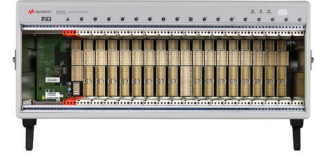

Step 2. Choose enough slot blocker kits and EMC filler panels to fill every open slot *Recommended to achieve datasheet specifications*

- Y1212A Slot blocker kit: 5 slots



- Y1213A PXI EMC filler panel kit: 5 slots



Step 3. Choose a rack mount kit (optional)

- Y1215A Rack mount kit for M9018A 18-slot PXIe chassis

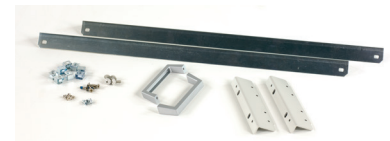

Step 4. Choose an air inlet kit¹ (optional)

Recommended for rack mounted systems with less than 1U space below chassis.

- Y1214A Air inlet kit: M9018A 18-slot chassis¹



1. Available in 1-slot, 2-slot or 3-slot options depending on the chassis configuration. For more information, please visit www.keysight.com/find/

E. Physical Connection Diagram for Controllers

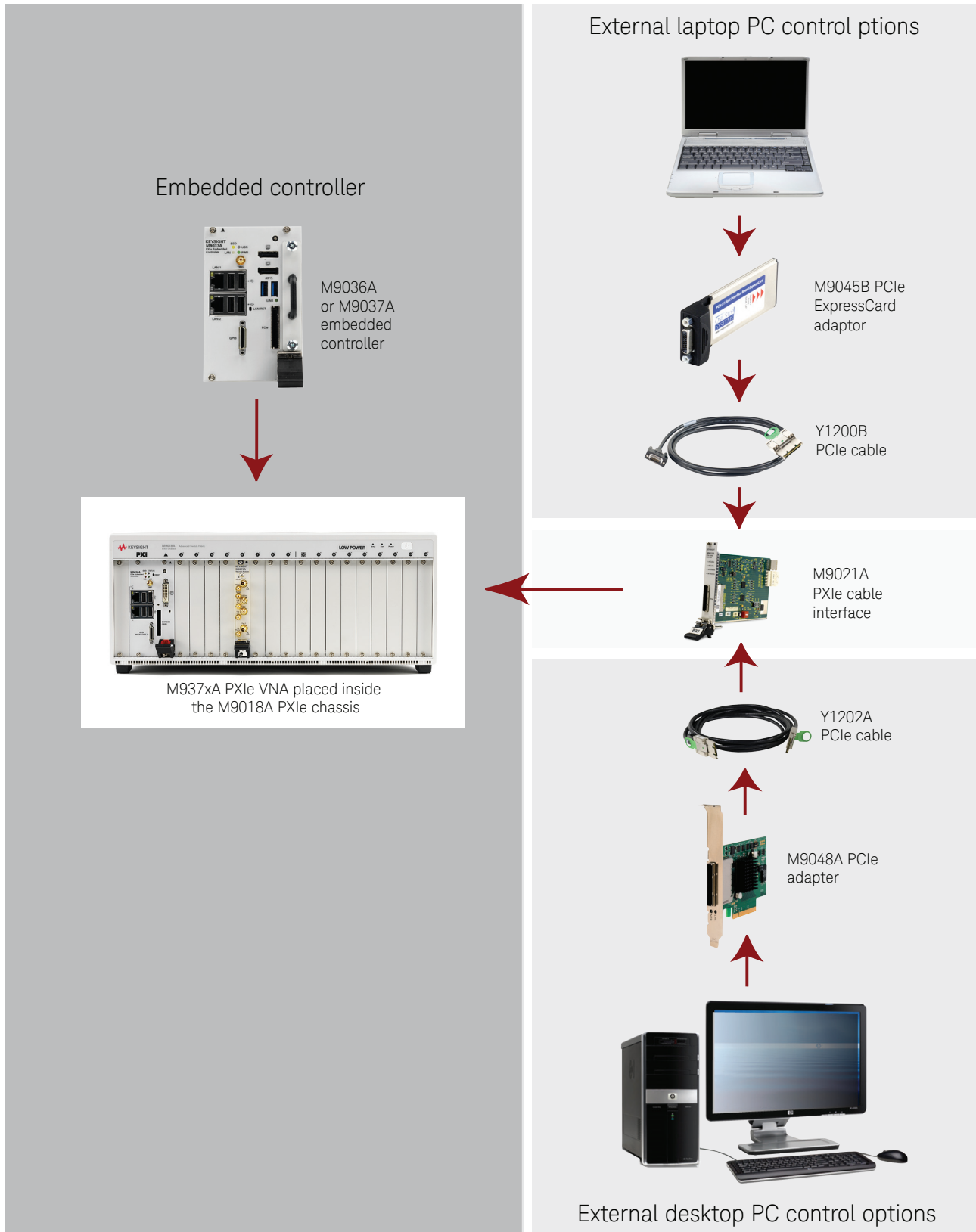

F. Select Software for M937xA PXIe VNA

Step 1. Start with M937xA base configuration

The M937xA comes standard with the following software:

- Keysight IO Libraries Suite including Connection Expert¹
- Instrument software, soft front panel, drivers for use with Matlab, LabVIEW, Visual Studio (including VB Net, C#, C/C++), Keysight VEE²
- Programming examples

Step 2. Download free Keysight Command Expert software³ (optional)

FREE software that provides fast and easy instrument control for the PC. Command Expert combines instrument command sets, command sequences, documentation, syntax checking, and command execution in one simple interface. Command Expert helps you to:

- Find instrument commands
- Access command documentation
- Verify command syntax
- Build instrument command sequences
- Execute instrument command sequences
- Integrate sequences in MATLAB, Visual Studio, Excel, LabVIEW, Keysight VEE or Keysight SystemVue PC application environment
- Generate code for command sequences in MATLAB, Visual C#, Visual Basic.NET and Visual C/C++
- Profile command execution time
- Debug command sequences using breakpoints and single stepping

1. Both IO library (version 16.3 or newer) and Connection Expert software need to be installed on the PC controlling the equipment.
To download, visit www.keysight.com/find/iosuite

2. Find latest versions of this software at www.keysight.com/find/pxivna

3. To download or get more information on Command Expert, visit www.keysight.com/find/commandexpert

G. Select Services: Warranty, Calibration, Start-up Assistance

Standard	Return to Keysight warranty - 3 years	
- R-51B-001-5Z	Return to Keysight warranty - 5 years	
- M937xA-UK6	Commercial calibration certification with test data	Complete set of measurements which tests unit to manufacturer's published specifications. Includes calibration label, calibration certificate, and data report. Conforms to ISO 9001.
- M937xA -1A7	ISO 17025 compliant calibration	Complete set of measurements which tests unit to manufacturer's published specifications. Includes calibration label, ISO 17025 calibration certificate, and data report, measurement uncertainties and guardbands on all customer specifications. Conforms to ISO 17025 and ISO 9001.
- M937xA -A6J	ANSI Z540 compliant calibration	Complete set of measurements which tests unit to manufacturer's published specifications. Includes pre- and post-adjustment data with measurement uncertainty information compliant to the ANSI/NCSL Z540 standard.
- M937xA -897	Perpetual license for built-in performance test software for Keysight inclusive cal	Adds built-in performance testing and calibration software for self-maintainers. Requires additional equipment. See the analyzer's Service Guide for more information on equipment required.
- M937xA -898	Perpetual license for built-in performance test software for Standards compliant cal	Adds built-in performance testing and calibration software for self-maintainers. Requires additional equipment. See the analyzer's Service Guide for more information on equipment required.
- R-51B-001-3X	Express warranty - 5 day turnaround For 3 years	Available in the US, Japan, China and many EU countries.
- R-51B-001-5X	Express warranty - 5 day turnaround For 5 years	Available in the US, Japan, China and many EU countries.

Global warranty

Keysight Technologies provides the peace of mind that today's high tech industry requires. Your investment is protected by Keysight's global reach in more than 100 countries (either directly or through distributors). The warranty gives you convenient standard coverage for the country in which the product is used, eliminating the need to ship equipment back to the country of purchase. Keysight's warranty service provides:

- All parts and labor necessary to return your investment to full specified performance
- Recalibration for products supplied originally with a calibration certificate
- Return shipment

Express warranty

Reduce downtime with the fastest repair service in the industry. The express warranty upgrades the global warranty to provide:

- 5 day typical turnaround repair service in the US, Japan, China and many EU countries or up to a 10 day improvement in turnaround time in the rest of the world
- Priority return shipment

Documentation

The PXI VNA is equipped with a Soft Front Panel help system in English only. This context-sensitive help is available in the software and on the CD. All PXI VNA documentation is available at: <http://na.support.keysight.com/pxivna/help>

Calibration services

The modular products are factory calibrated and shipped with an ISO-9002, NIST-traceable calibration certificate. A one year calibration cycle is recommended. The M937xA PXIe VNA is supported by the Keysight N7800A Calibration Software to perform calibrations that test all product specifications and is compliant with ISO 17025:2005, ANSI/NCSL Z540.3-2006 and Measurement Uncertainty per ISO Guide to Expression of Measurement Uncertainty 1995.

N7800A calibration and adjustment software

The M937xA PXIe VNA is supported by Keysight's calibration and adjustment software. This is the same software used at Keysight's service centers to automate calibration. The software offers compliance tests for ISO 17025:2005, ANSI/NCSL Z540.3-2006, and measurement uncertainty per ISO Guide to Expression of Measurement Uncertainty.

Product Information:	www.keysight.com/find/contactus
Or call:	1 800 829-4444 US
Repair and Calibration:	www.keysight.com/find/infoline
Parts and Accessories:	www.parts.keysight.com
Email Updates:	www.keysight.com/find/emailupdate
For all modular products:	www.keysight.com/find/modular

H. Measurement Accessories

A complete list of RF and microwave test accessories is available on our web site: www.keysight.com/find/mta.

Accessories are available in these connector types: 50 ohm Type-N, 3.5 mm, 7 mm, and waveguide. Test port cables and a calibration kit should be added for a complete measurement system. A verification kit is used to verify corrected system performance.

Cables and adapter sets

Keysight offers cables in the following types:

- Single cables in semi-rigid and flexible
- Cable sets in semi-rigid and flexible

There are also adapter sets available that protect the test port and convert the port to the desired connector interface. These kits contain:

- One male adapter
- One female adapter

To attain the best mechanical rigidity for device connection, use a single cable and the appropriate special adapter set. To attain the greatest flexibility for device connection, use a cable set.

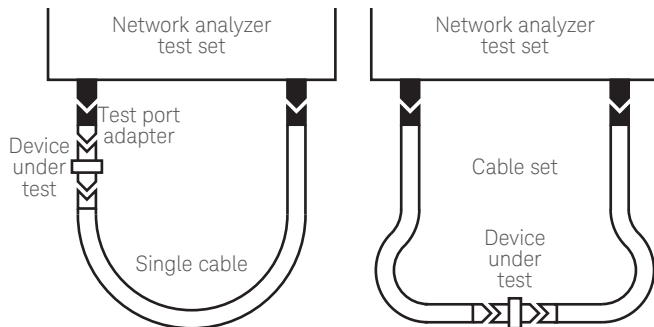

Calibration kits

Coaxial measurements

Mechanical calibration kits include standards, such as opens, shorts and loads, which are measured by the network analyzer for increased measurement accuracy.

Electronic calibration (ECal) kits replace mechanical calibration standards with one solid-state calibration module that is controlled by the network analyzer via USB, to present many different impedances to the test ports. A full two-port calibration can be performed quickly with a single connection. This technique reduces operator errors and connector wear and abrasion.

Choose a calibration kit for each connector type to be used.

Economy, includes:

- Open standards (male and female)
- Short standards (male and female)
- Fixed-termination standards (male and female)

Standard, includes the devices in the economy kit and adds:

- Sliding load standards (male and female) or a series of offset shorts

Precision, includes the devices in the economy kit and adds:

- 50 ohm airline(s) for TRL calibration
- TRL adapters

Waveguide measurements

For waveguide measurements, Keysight offers mechanical calibration kits that include:

- Waveguide-to-coax adapters (X, P, K)
- Precision waveguide section
- Flush short circuit
- Fixed terminations
- Straight section

For devices with 3.5 mm or SMA connectors

Mechanical calibration kits

- **85052B** Standard, DC to 26.5 GHz
Includes:
00902-60003 3.5 mm (m) fixed load
00902-60004 3.5 mm (f) fixed load
00911-60019 3.5 mm (m) sliding load
00911-60020 3.5 mm (f) sliding load
85052-60006 3.5 mm (m) short
85052-60007 3.5 mm (f) short
85052-60008 3.5 mm (m) open
85052-60009 3.5 mm (f) open
85052-60012 3.5 mm (f) to 3.5 mm (f) adapter
85052-60013 3.5 mm (f) to 3.5 mm (m) adapter
85052-60014 3.5 mm (m) to 3.5 mm (m) adapter
- **85052C** Precision TRL, DC to 26.5 GHz
Includes:
00902-60003 3.5 mm (m) fixed load
00902-60004 3.5 mm (f) fixed load
85052-60006 3.5 mm (m) short
85052-60007 3.5 mm (f) short
85052-60008 3.5 mm (m) open
85052-60009 3.5 mm (f) open
85052-60032 3.5 mm (f) to 3.5 mm (f) adapter
85052-60033 3.5 mm (m) to 3.5 mm (m) adapter
85052-60034 3.5 mm (f) to 3.5 mm (m) adapter
85052-60035 3.5 mm short TRL line
85052-60036 3.5 mm long TRL line
- **85052D** Economy, DC to 26.5 GHz
Includes:
00902-60003 3.5 mm (m) fixed load
00902-60004 3.5 mm (f) fixed load
85052-60006 3.5 mm (m) short
85052-60007 3.5 mm (f) short
85052-60008 3.5 mm (m) open
85052-60009 3.5 mm (f) open
85052-60012 3.5 mm (f) to 3.5 mm (f) adapter
85052-60013 3.5 mm (f) to 3.5 mm (m) adapter
85052-60014 3.5 mm (m) to 3.5 mm (m) adapter

Electronic calibration kits

- **85093C** RF ECal, 300 kHz to 9 GHz, 2-ports
Standard module includes
Option M0F with:
85093-60008 3.5 mm (f) to 3.5 mm (m) ECal module
Option 00F module with:
85093-60010 3.5 mm (f) to 3.5 mm (f) ECal module
Option 00M module with:
85093-60009 3.5 mm (m) to 3.5 mm (m) ECal module
Option 00A adds:
85052-60012 3.5 mm (f) to 3.5 mm (f) adapter
85052-60014 3.5 mm (m) to 3.5 mm (m) adapter

85093C-xxx mixed-connector options:

Port A option			Port B option					
Type	(f)	(m)	Type	(f)	(m)	Type	(f)	(m)
3.5 mm	101	102	Type-N 50 ohm	203	204	7-16	205	206

- **N4431B** Microwave ECal, 300 kHz to 13.5 GHz, 4-ports
Includes:
Option 010 module with:
N4431-60006 4 x 3.5 mm (f) ECal module

N4431B-xxx mixed-connector options:

Connector	Port A	Port B	Port C	Port D
Type	Option	Option	Option	Option
3.5 mm (f)	101	201	301	401
3.5 mm (m)	102	202	302	402
Type-N 50 ohm (f)	103	203	303	403
Type-N 50 ohm (m)	104	204	304	404
7-16 (f)	105	205	305	405
7-16 (m)	106	206	306	406

- **N4433A** Microwave ECal, 300 kHz to 20 GHz, 4-ports
Includes:
Option 010 module with:
N4433-60003 4 x 3.5 mm (f) ECal module

N4433A-xxx mixed-connector options:

Connector	Port A	Port B	Port C	Port D
Type	Option	Option	Option	Option
3.5 mm (f)	101	201	301	401
3.5 mm (m)	102	202	302	402

- **N4691B** Microwave ECal, 300 kHz to 26.5 GHz, 2-ports
Includes:
Option M0F module with:
N4691-60004 3.5 mm (f) to 3.5 mm (m) ECal module
Option 00M module with:
N4691-60005 3.5 mm (m) to 3.5 mm (m) ECal module
Option 00F module with:
N4691-60006 3.5 mm (f) to 3.5 mm (f) ECal module
Option 00A adds:
85052-60012 3.5 mm (f) to 3.5 mm (f) adapter
85052-60014 3.5 mm (m) to 3.5 mm (m) adapter

For devices with Type-N connectors

Mechanical calibration kits

- **85054B** Standard, DC to 18 GHz
Includes:
00909-60011 Type-N (m) fixed lowband load
00909-60012 Type-N (f) fixed lowband load
85054-60025 Type-N (m) short
85054-60026 Type-N (f) short
85054-60027 Type-N (m) open
85054-60028 Type-N (f) open
85054-60031 Type-N (f) to 7mm adapter
85054-60032 Type-N (m) to 7mm adapter
85054-60037 Type-N (f) to Type-N (f) adapter
85054-60038 Type-N (m) to Type-N (m) adapter
85054-80010 Type-N (f) sliding load
85054-80009 Type-N (m) sliding load
85054-60050 Type-N (f) connector gage
85054-60052 Type-N (f) gage master
85054-60051 Type-N (m) connector gage
85054-60053 Type-N (m) gage master
- **85054D** Economy, DC to 18 GHz
Includes:
85054-60025 Type-N (m) short
85054-60026 Type-N (f) short
85054-60027 Type-N (m) open
85054-60028 Type-N (f) open
85054-60031 Type-N (f) to 7mm adapter
85054-60032 Type-N (m) to 7mm adapter
85054-60037 Type-N (f) to Type-N (f) adapter
85054-60038 Type-N (m) to Type-N (m) adapter
85054-60046 Type-N (m) fixed load
85054-60047 Type-N (f) fixed load

Electronic calibration kits

- **N4431B** Microwave ECal, 300 kHz to 13.5 GHz, 4-ports
Includes:
Option 020 module with:
N4431-60007 4 x Type-N (f) ECal module

N4431B-xxx mixed-connector options:

Connector	Port A	Port B	Port C	Port D
Type	Option	Option	Option	Option
3.5 mm (f)	101	201	301	401
3.5 mm (m)	102	202	302	402
Type-N 50 ohm (f)	103	203	303	403
Type-N 50 ohm (m)	104	204	304	404
7-16 (f)1	105	205	305	405
7-16 (m)1	106	206	306	406

- **N4432A** Microwave ECal, 300 kHz to 18 GHz, 4-ports
Includes:
Option 020 module with:
N4432-60003 4 x Type-N (f) ECal module

N4432A-xxx mixed-connector options:

Connector	Port A	Port B	Port C	Port D
Type	Option	Option	Option	Option
3.5 mm (f)	101	201	301	401
3.5 mm (m)	102	202	302	402
Type-N 50 ohm (f)	103	203	303	403
Type-N 50 ohm (m)	104	204	304	404

- **N4690B** Microwave ECal, 300 kHz to 18 GHz, 2-ports
Includes:
Option M0F module with:
N4690-60004 Type-N (f) to Type-N (m) ECal module
Option 00M module with:
N4690-60005 Type-N (m) to Type-N (m) ECal module
Option 00F module with:
N4690-60006 Type-N (f) to Type-N (f) ECal module
Option 00A adds:
85054-60037 Type-N (f) to Type-N (f) adapter
85054-60038 Type-N (m) to Type-N (m) adapter

For devices with 7 mm connectors

Mechanical calibration kits

- **85050B** Standard, DC to 18 GHz
Includes:
00909-60008 7 mm coax termination
85050-60006 7 mm fixed broadband load
85050-80007 7 mm short
85050-80010 7 mm open
85050-80011 7 mm sliding load
- **85050C** Precision TRL, DC to 18 GHz
Includes:
00909-60008 7 mm coax termination
85050-60003 7 mm to 7 mm airline
85050-60005 7 mm to 7 mm TRL adapter
85050-60006 7 mm fixed broadband load
85050-80008 7 mm short
85050-80009 7 mm short collet
85050-80010 7 mm open
- **85050D** Economy, DC to 18 GHz
Includes:
85050-60006 7 mm fixed broadband load
85050-80007 7 mm short
85050-80010 7 mm open

Electronic calibration kits

- **N4696B** Microwave ECal, 300 kHz to 18 GHz, 2-ports,
7 mm to 7 mm microwave module

For devices with waveguide

Mechanical calibration kits

X Band

- **X11644A** Standard WR-90, 8.2 to 12.4 GHz
Includes:
00896-60008 X-band standard section
00910-60003 X-band termination
11644-20018 X-band short
11644-20021 X-band shim

P-Band

- **P11644A** Standard WR-62, 12.4 to 18 GHz
Includes:
00896-60007 P-band standard section
00910-60002 P-band termination
11644-20017 P-band short
11644-20020 P-band shim

K-Band

- **K11644A** Standard WR-42, 18 to 26.5 GHz
Includes:
00896-60006 K-band standard section
00910-60001 K-band termination
11644-20016 K-band short
11644-20019 K-band shim

Verification kits

All Keysight verification kits include:

- Precision Z0 airline or match thru
- Mismatched airline or mismatch thru
- Fixed attenuators
- Traceable measured data and uncertainties
- **85051B** 45 MHz to 18 GHz 7 mm kit
Includes attenuators, airline and mismatch airline with data on a 3.5-inch disk for use in confirming accuracy enhanced system measurement performance, traceable to national standards. Test procedure is provided in the service manual.
- **85053B** 300 kHz to 26.5 GHz 3.5 mm kit
Includes attenuators, airline and mismatch airline with data on a 3.5-inch disk for use in confirming accuracy enhanced system measurement performance, traceable to national standards. Test procedure is provided in the service manual.
- **85055A** 300 kHz to 18 GHz Type-N kit
Includes attenuators, airline and mismatch airline with data on a 3.5-inch disk for use in confirming accuracy enhanced system measurement performance, traceable to national standards. Test procedure is provided in the service manual.

I. Example Configurations

Please see the M937xA Startup Guide literature number M9370-90001 for detailed cabling diagram and parts list.

Single 2-port M937xA PXIe VNA



Multiport Measurement Configurations

The Keysight PXI VNA is an ideal solution for multiport measurements. The PXI VNA has a two-port (two reference receivers and two test receivers) architecture in a one-slot module. It can be easily configured as a true multiport VNA by using additional modules installed in the same chassis. The true multiport VNA has no degradation in performance (i.e. dynamic range, trace noise, directivity,..) due to external switches. The PXI VNA supports full N-port correction capability when configured as a multiport VNA.

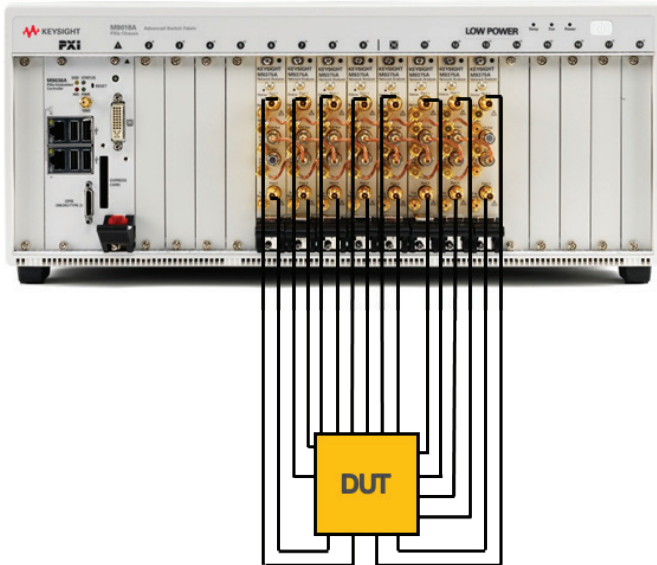

Figure 1. The Keysight PXI VNA is an ideal solution for multiport measurements. Easy to configure, better performance, and much faster speed!

When multiple M937xA modules are used in the following configurations they are configured for multiport operation. The modules may be installed in one chassis and identified by the M937xA firmware as one VNA under a single PXI controller. At least one VNA module in the chassis must have Option 551 (N-Port Calibrated Measurements) to maintain N-port capabilities. The frequency of the multiport array is determined by the lowest frequency module configured in the array. For example, a 4-port analyzer configuration using an M9370A (4 GHz) and an M9375A (26.5 GHz) would have a maximum frequency of 4 GHz when performing 4-port measurements.

This behavior extends to Option 010 and 102. In a multiport configuration only one module must have a valid license for these capabilities to function in multiport mode. However, in a multi-site configuration a license must be purchased for each independent VNA configuration.

Each module is connected into the array with Keysight cables. A Y1242A multiport cable kit should be ordered for each additional module and a single Y1281 accessory and tool kit should be ordered for easier cable connections.

Additional cables and accessories for multiport connections:

Y1242A Multiport cable kit
Includes 2 SMB cables and 1 SMA cable for connecting 2 modules together.
Add one multiport cable kit for each additional 2-port VNA

Y1281A Accessory and tool kit
Includes the following tools for SMA and SMB connector removal:
5002-3361 Pull tool for SMB connectors
5023-1450 Custom long deep socket for 3.5/SMA connector nuts

Multi-site Measurement Configurations

The Keysight M937xA multi-site capability allows for each PXI module to behave as an independent VNA. This makes it possible to run measurements of different devices at the same time or different measurement paths in a single component. In addition, segment sweep enables you to optimize measurement conditions specifically for each device under test, so you can balance speed and accuracy.

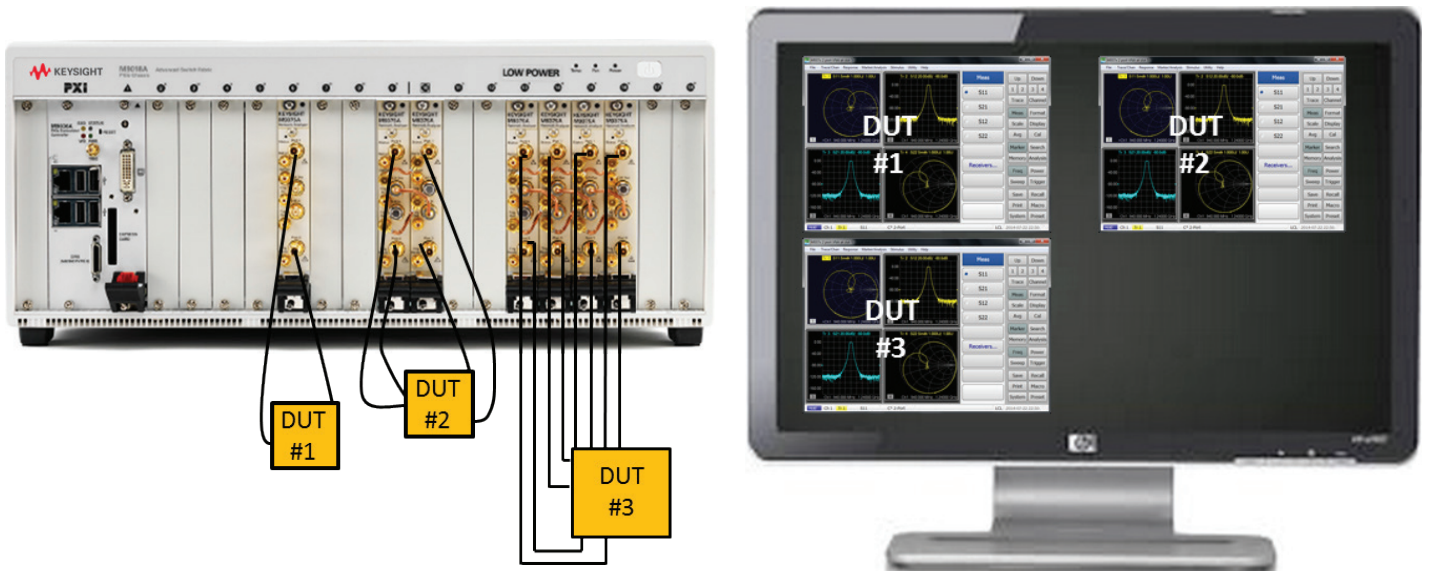

Figure 2. Example of an 8-port multiport VNA, a 2-port VNA, and a 4-port VNA running under three separate copies of the software all executing simultaneously in multi-site operation on the same controller.

For multi-site configurations that require Option 010, a valid license is required for at least one module in each independent VNA configuration.

The Y1242A multiport cable kit only needs to be ordered when modules are used in a multiport configuration.

Upgrading your system

Your product can be easily upgraded after the initial purchase. Contact your Keysight representative to place an order for an option upgrade.

	Order for existing model number					
	M9370A	M9371A	M9372A	M9373A	M9374A	M9375A
Extend analyzer's frequency range to 6.5 GHz	M9370AU-706	n/a	n/a	n/a	n/a	n/a
Extend analyzer's frequency range to 9 GHz	M9370AU-709	M9371AU-709	n/a	n/a	n/a	n/a
Extend analyzer's frequency range to 14 GHz	M9370AU-714	M9371AU-714	M9372AU-714	n/a	n/a	n/a
Extend analyzer's frequency range to 20 GHz	M9370AU-720	M9371AU-720	M9372AU-720	M9373AU-720	n/a	n/a
Extend analyzer's frequency range to 26.5 GHz	M9370AU-726	M9371AU-726	M9372AU-726	M9373AU-726	M9374AU-726	n/a
Add time domain capability	M9370AU-010	M9371AU-010	M9372AU-010	M9373AU-010	M9374AU-010	M93745U-010
Add full n-port correction capability	M9370AU-551	M9371AU-551	M9372AU-551	M9373AU-551	M9374AU-551	M93745U-551

Using a Non-Keysight Chassis

The M937xA can be successfully installed in a non-Keysight PXI chassis. Please use the following guidelines.

- Ensure that the chassis has an available PXIe or PXI-H slot which can be used by the M937xA.
- Ensure that the chassis and controller supports peer-to-peer PXI Express I/O switch topology.
- Ensure that controller selected is compatible with chassis.

Please contact your Keysight representative for more detailed information. For technical assistance with non-Keysight equipment, please refer to the equipment manufacturer's website.

PC Requirements for M937xA PXIe VNA Control¹

	Windows 7 and Vista
Operating system	Windows 7 (32 & 64 bit) Windows Vista, SP 1 & 2 (32 & 64 bit)
Processor speed	1.5 GHz dual core (x86 or x64) minimum, 2.4 GHz recommended
Available memory	1 GB minimum 8 GB recommended
Available disk space	1.5 GB available hard disk space

Related Literature

For more detailed product and specification information refer to the following literature and web pages:

M937xA PXIe VNA, Data Sheet, M9370-90002

M937xA PXIe VNA, Startup Guide, M9370-90001

M937xA PXIe VNA, Brochure, 5992-0098EN

M937xA PXIe VNA, Flyer/Photo Card, 5991-4883EN

M9018A PXIe 18 slot Chassis, Data Sheet, 5990-6583EN

M9037A PXIe High Performance Embedded Controller, Data Sheet, 5991-3661EN

M9036A PXIe Embedded Controller, Data Sheet, 5990-8465EN

1. For a list of computers compatible with Keysight Technologies PXIe M9018A chassis, refer to Tested Computer Technical Note (literature no. 5990-7632EN).

From Hewlett-Packard through Agilent to Keysight

For more than 75 years, we've been helping you unlock measurement insights. Our unique combination of hardware, software and people can help you reach your next breakthrough. [Unlocking measurement insights since 1939.](#)

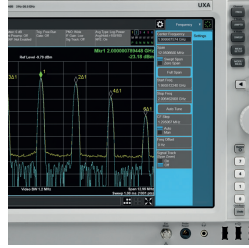
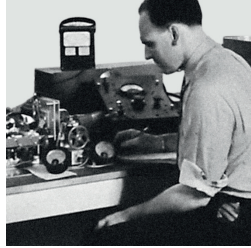

1939

THE FUTURE

For more information on Keysight Technologies' products, applications or services, please contact your local Keysight office. The complete list is available at: www.keysight.com/find/contactus

Americas

Canada (877) 894 4414
 Brazil 55 11 3351 7010
 Mexico 001 800 254 2440
 United States (800) 829 4444

Asia Pacific

Australia 1 800 629 485
 China 800 810 0189
 Hong Kong 800 938 693
 India 1 800 11 2626
 Japan 0120 (421) 345
 Korea 080 769 0800
 Malaysia 1 800 888 848
 Singapore 1 800 375 8100
 Taiwan 0800 047 866
 Other AP Countries (65) 6375 8100

Europe & Middle East

Austria 0800 001122
 Belgium 0800 58580
 Finland 0800 523252
 France 0805 980333
 Germany 0800 6270999
 Ireland 1800 832700
 Israel 1 809 343051
 Italy 800 599100
 Luxembourg +32 800 58580
 Netherlands 0800 0233200
 Russia 8800 5009286
 Spain 800 000154
 Sweden 0200 882255
 Switzerland 0800 805353
 Opt. 1 (DE)
 Opt. 2 (FR)
 Opt. 3 (IT)
 United Kingdom 0800 0260637

For other unlisted countries:
www.keysight.com/find/contactus
 (BP-01-01-16)



www.keysight.com/go/quality
 Keysight Technologies, Inc.
 DEKRA Certified ISO 9001:2008
 Quality Management System

This information is subject to change without notice.
 © Keysight Technologies, 2014, 2016
 Published in USA, January 20, 2016
 5991-4885EN
www.keysight.com

myKeysight

myKeysight

www.keysight.com/find/mykeysight
 A personalized view into the information most relevant to you.

www.pxisa.org



PCI eXtensions for Instrumentation (PXI) modular instrumentation delivers a rugged, PC-based high-performance measurement and automation system.

Three-Year Warranty



www.keysight.com/find/ThreeYearWarranty
 Keysight's committed to superior product quality and lower total cost of ownership. Keysight is the only test and measurement company with a three-year warranty standard on all instruments, worldwide. And, we provide a one-year warranty on many accessories, calibration devices, systems and custom products.

Keysight Assurance Plans



www.keysight.com/find/AssurancePlans
 Up to ten years of protection and no budgetary surprises to ensure your instruments are operating to specification, so you can rely on accurate measurements.

Keysight Infoline

Keysight Infoline

www.keysight.com/find/service
 Keysight's insight to best in class information management. Free access to your Keysight equipment company reports and e-library.

Keysight Channel Partners

www.keysight.com/find/channelpartners
 Get the best of both worlds: Keysight's measurement expertise and product breadth, combined with channel partner convenience.

www.keysight.com/find/pxivna